



DOWSIL™ 796 Neutral Silicone

Neutral silicone sealant

Features & Benefits

- Good unprimed adhesion to a variety of substrates
- Low modulus, high elasticity
- 100% silicone sealant
- Neutral cure
- Low odor
- Conforms to ISO 11600-F&G-25LM
- Resistant to ozone, ultra-violet radiation and temperature extremes

Applications

- DOWSIL™ 796 Neutral Silicone is a one-part, low modulus, neutral curing silicone sealant specifically developed for the sealing of PVC-U, glass, glazed surfaces and brickwork. It is very popular for perimeter sealing applications of windows and doors.

Typical Properties

Specification Writers: These values are not intended for use in preparing specifications.

Test ¹	Property	Unit	Result
	Cure system		Alkoxy
	Application temperature	°C °F	+5 to +40 +41 to +104
CTM 97B	Specific gravity		1.52
CTM 364C	Extrusion rate	g/minute	210
CTM 98B	Skin-over time (23°C or 73°F, 50% R.H.)	minutes	15
CTM 95A	Tack-free time (23°C or 73°F, 50% R.H.)	minutes	35
CTM 663A	Cure rate (23°C or 73°F, 50% R.H.)		
	1 day	mm	2.0
	3 days	mm	3.5
2 mm thickness S2 dumb-bells (ISO² 37/DIN³ 53 504)			
CTM 137A	E-modulus 100%	MPa	0.45
CTM 137A	Tensile strength	MPa	1.8
CTM 137A	Elongation at break	%	700

1. CTM: Corporate Test Method, copies of CTMs are available on request.
2. ISO: International Standardisation Organisation
3. DIN: Deutsche Industrie Norm

Typical Properties (Cont.)

Test	Property	Unit	Result
12 x 12 x 50 mm size T.A. joint (ISO 8339/DIN 2-8339)			
CTM 677	E-modulus 100%	MPa	0.35
CTM 677	Tensile strength	MPa	0.75
CTM 677	Elongation at break	%	380
CTM 99E	Hardness (Shore A)		30
ISO 7389	Elastic recovery	%	> 90
ISO 9047	Joint movement capability	%	± 25

Technical Specifications and Standards

- Conforms to SNJF (F&G – 25E)
- ISO 11600-F&G-25LM
- EN 15651 - CE MARK



Regulation or protocol	Conclusion	Version of regulation or protocol
French VOC régulations	A+	Regulation of March and May 2011 (DEVL1101903D and DEVL1104875A)
French CMR components	Pass	Regulation of April and May 2009 (DEVP0908633A and DEVP0910046A)
Italian CAM Edilizia	Pass	Decree 11 January 2017 (GU n.23 del 28-1-2017)
AgBB/ABG	Pass	Anforderungen an bauliche Anlagen bezoglich des Gesundheitsschutzes (ABG), Entwurf 31.08.2017/August 2018 (AgBB)
Belgian Regulation	Pass	Royal decree of May 2014 (C-2014/24239)
EMICODE	EC1 Plus	April 2019
Indoor Air Comfort	Pass	Indoor Air Comfort 6.0 of February 2017
Indoor Air Comfort GOLD	Pass	Indoor Air Comfort GOLD 6.0 of February 2017
Blue Angel (DE-UZ 123)	Pass	DE-UZ 123 for "Low-Emission Sealants for Interior Use", (January 2019)
BREEAM International	Exemplary lvl	BREEAM International New Construction v2.0 (2016)
BREEAM Norway	Pass	BREEAM-NOR New Construction v1.2 (2019)
CDPH	Pass	
M1	Pass	
Byggarubedomningen	Accepted	

How to Use

Surface Preparation

Ensure that surfaces to be sealed are clean, dry, sound and free from frost. Clean all joints of release agents, water repellents, laitance, dust, dirt, old sealants and other contaminants which could impair adhesion. Non-porous surfaces should be cleaned and degreased by wiping with a suitable solvent such as DOWSIL™ R-40 Universal Cleaner on an oil and lint-free cloth before application of sealant. Porous substrates should be mechanically cleaned using a steel brush, sanding disc or any similar means.

Note: When using any solvent, always provide adequate ventilation. Avoid heat, sparks and open flames. Use solvent resistant gloves. Observe and follow all precautions listed on solvent container label.

Masking

Areas adjacent to the joints should be masked with tape to prevent contamination of the substrates and to ensure a neat sealant line. Masking tape should be removed immediately after tooling.

Priming

No primer is required for PVC-U and for most common construction substrates including brick. However, a test placement prior to general use is always recommended.

Back-up Materials

Closed cell polyethylene backer rod is recommended as a back-up material to provide back pressure and avoid three sided adhesion that limits sealant movement capability. Low tack polyethylene tape should be used in joints too shallow to allow the use of backer rod.

Finishing

The joint should be tooled within 5 minutes of application to ensure good contact between the sealant and the substrate. Tooling of the sealant also gives a smooth, professional finish.

Clean-up

Excess sealant may be cleaned off tools and non-porous surfaces whilst in an uncured state using DOWSIL™ R-40 Universal Cleaner. If sealant is misapplied to porous substrates, it should be left until it is just cured and then removed by peeling, cutting or other mechanical means. Care should be taken not to damage plastic or coated surfaces.

Joint Design

The sealant joint width should be designed to accommodate the movement capability of the sealant. When designing joints using DOWSIL™ 796 Neutral Silicone, the minimum width should be 6 mm. For joints between 6–12 mm wide, a seal depth of 6 mm is required. For joints above 12 mm wide, a width to depth ratio of 2:1 should be used. For joint dimensions greater than 25 mm, please contact your regional service center for technical assistance. In situations where fillet joints are needed, a minimum of 6 mm sealant bite to each substrate is recommended.

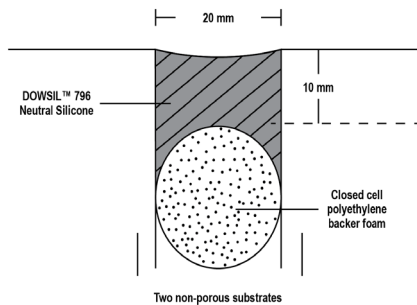

Figure 1: Deep joint.

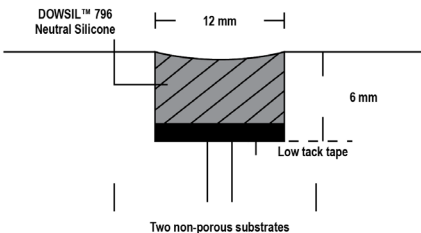

Figure 2: Shallow joint.

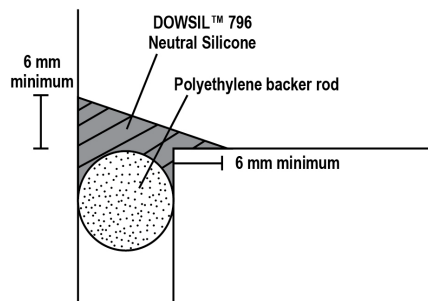

Figure 3: Fillet joint.

Handling Precautions

PRODUCT SAFETY INFORMATION REQUIRED FOR SAFE USE IS NOT INCLUDED IN THIS DOCUMENT. BEFORE HANDLING, READ PRODUCT AND SAFETY DATA SHEETS AND CONTAINER LABELS FOR SAFE USE, PHYSICAL AND HEALTH HAZARD INFORMATION. THE SAFETY DATA SHEET IS AVAILABLE ON THE DOW WEBSITE AT DOW.COM, OR FROM YOUR DOW SALES APPLICATION ENGINEER, OR DISTRIBUTOR, OR BY CALLING DOW CUSTOMER SERVICE.

Usable Life and Storage

When stored at or below 30°C (86°F) in the original unopened containers, DOWSIL™ 796 Neutral Silicone has a usable life of 12 months from the date of production.

Limitations

DOWSIL™ 796 Neutral Silicone is not recommended for structural glazing or insulated glazing applications. Do not use DOWSIL™ 796 Neutral Silicone on bituminous substrates, substrates based on natural rubber, chloroprene or EPDM or on building materials which might bleed oils, plasticisers or solvents. Do not use DOWSIL™ 796 Neutral Silicone in a totally confined space because the sealant requires atmospheric moisture to cure. It is not recommended for use on submerged joints, or in joints where physical abuse or abrasion are likely to occur. Bleeding can occur on porous substrates, such as concrete, marbles, granites and other natural stones. Specific testing should be carried out on sensitive substrates.

DOWSIL™ 796 Neutral Silicone is not suitable for food contact applications.

It is recommended that DOWSIL™ 796 Neutral Silicone is not applied to surfaces that are below 5°C (41°F) as it is impossible to guarantee a dry surface at these temperatures.

This product is neither tested nor represented as suitable for medical or pharmaceutical uses.

Health and Environmental Information

To support customers in their product safety needs, Dow has an extensive Product Stewardship organization and a team of product safety and regulatory compliance specialists available in each area.

For further information, please see our website, dow.com or consult your local Dow representative.

Disposal Considerations

Dispose in accordance with all local, state (provincial) and federal regulations. Empty containers may contain hazardous residues. This material and its container must be disposed in a safe and legal manner.

It is the user's responsibility to verify that treatment and disposal procedures comply with local, state (provincial) and federal regulations. Contact your Dow Technical Representative for more information.

Product Stewardship

Dow has a fundamental concern for all who make, distribute, and use its products, and for the environment in which we live. This concern is the basis for our product stewardship philosophy by which we assess the safety, health, and environmental information on our products and then take appropriate steps to protect employee and public health and our environment. The success of our product stewardship program rests with each and every individual involved with Dow products - from the initial concept and research, to manufacture, use, sale, disposal, and recycle of each product.

Customer Notice

Dow strongly encourages its customers to review both their manufacturing processes and their applications of Dow products from the standpoint of human health and environmental quality to ensure that Dow products are not used in ways for which they are not intended or tested. Dow personnel are available to answer your questions and to provide reasonable technical support. Dow product literature, including safety data sheets, should be consulted prior to use of Dow products. Current safety data sheets are available from Dow.

dow.com

NOTICE: No freedom from infringement of any patent owned by Dow or others is to be inferred. Because use conditions and applicable laws may differ from one location to another and may change with time, Customer is responsible for determining whether products and the information in this document are appropriate for Customer's use and for ensuring that Customer's workplace and disposal practices are in compliance with applicable laws and other government enactments. The product shown in this literature may not be available for sale and/or available in all geographies where Dow is represented. The claims made may not have been approved for use in all countries. Dow assumes no obligation or liability for the information in this document. References to "Dow" or the "Company" mean the Dow legal entity selling the products to Customer unless otherwise expressly noted. NO WARRANTIES ARE GIVEN; ALL IMPLIED WARRANTIES OF MERCHANTABILITY OR FITNESS FOR A PARTICULAR PURPOSE ARE EXPRESSLY EXCLUDED.





陶熙™796门窗安装系统硅酮密封胶

DOWSIL™ 796 Window and Door
Installation System Silicone Sealant



黑色 Black



白色 white



灰色 Gray



半透明 Translucent



深灰色 Dark gray(03A)



古铜色 Bronze(47A)



古铜色 Bronze(48A)



*注：色板仅供参考，因光线及角度不同会存在些许差异，属于正常现象，请以实际施工效果为准。

FUGRO TECHNICAL SERVICES LIMITED

Fugro Development Centre,
5 Lok Yi Street, Tai Lam,
Tuen Mun, N.T.,
Hong Kong.

Tel : +852 2450 8233
Fax : +852 2450 6138
E-mail : matlab@fugro.com
Website : www.fugro.com

MaterialLab

Client Ref. : --
Report No. : 180217ST180205A

Page 1 of 20

1.0 Introduction

Fugro Technical Services Limited was commissioned by the client, [REDACTED] to conduct a series of tests on sealant to BS 5889 : 1989 and BS 3712 : 1985.

The test sample was given the laboratory I.D.: ST180205 was received by Fugro Technical Services Limited on 13 March 2018 AND 29 June 2018.

Description of Sample: DOWSIL 796 Neutral Silicone
Primer A : DOWSIL CONSTRUCTION PRIMER P (For Cement Mortar)
/Primer B : DOWSIL 1200 OS PRIMER CLEAR (For Clear float glass and Aluminium)

2.0 Summary of Test Results

Test Item		Test Method	Type Test	Primer	Test Surface	Lab Sample I.D.	Test Results
Skin forming test		Appendix A of BS 5889 : 1989	--	--	--	ST180205/1-2	Pass
Slump properties		BS 3712 : Part 1 : 1985, clause 8	--	--	--	ST180205/3-6	Pass
Extrusion rate		BS 3712 : Part 1 : 1985, clause 6	--	--	--	ST180205/8-9	Pass
Tensile Extension Properties	(A) Force on Extension at 23 ± 2°C	BS 3712 : Part 4 : 1985, 4.4.1	A and B	--	Clear Float Glass	ST180205/10-12	Pass
	(B) Elastic recovery	BS 3712 : Part 4 : 1985, 4.4.3	A	--	Clear Float Glass	ST180205/13-15	Pass
			B	--	Clear Float Glass	ST180205/16-18	Pass
Loss of Mass After Heat Ageing		BS 3712 : Part 4 : 1985, clause 5	--	--	--	ST180205/19-21	Pass
Initial Adhesion Test		BS 5889 : 1989, B5	A	--	Clear Float Glass	ST180205/22-24	Pass
			A	B	Aluminium	ST180205/85-87	Pass
			A	A	Cement Mortar (with primer)	ST180205/28-30	Pass
			B	--	Clear Float Glass	ST180205/31-33	Pass
			B	B	Aluminium	ST180205/76-78	Pass
			B	A	Cement Mortar (with primer)	ST180205/37-39	Pass
Cyclic Adhesion Test		BS 5889 : 1989, B6	A	B	Clear Float Glass (with primer)	ST180205/88-90	Pass
			A	B	Aluminium (with primer)	ST180205/91-93	Pass
			A	A	Cement Mortar (with primer)	ST180205/46-48	Pass

FUGRO TECHNICAL SERVICES LIMITED

Fugro Development Centre,
5 Lok Yi Street, Tai Lam,
Tuen Mun, N.T.,
Hong Kong.

Tel : +852 2450 8233
Fax : +852 2450 6138
E-mail : matlab@fugro.com
Website : www.fugro.com

MaterialLab

**REPORT ON
PERFORMANCE TEST
OF SILICONE SEALANT**

Client : 

Project : Testing of Sealant

Client Ref. : --

Report No. : 171832ST170356(1)

Date : 31 October 2017

FUGRO TECHNICAL SERVICES LIMITED

Fugro Development Centre,
5 Lok Yi Street, Tai Lam,
Tuen Mun, N.T.,
Hong Kong.

Tel : +852 2450 8233
Fax : +852 2450 6138
E-mail : matlab@fugro.com
Website : www.fugro.com

MaterialLab

CONTENT

- 1.0 Introduction
- 2.0 Summary of Test Results
- 3.0 Individual Results
- 4.0 Record Photographs

FUGRO TECHNICAL SERVICES LIMITED

Fugro Development Centre,
5 Lok Yi Street, Tai Lam,
Tuen Mun, N.T.,
Hong Kong.

Tel : +852 2450 8233
Fax : +852 2450 6138
E-mail : matlab@fugro.com
Website : www.fugro.com

MaterialLab

Client Ref. : --
Report No. : 171832ST170356(1)

Page 1 of 5

1.0 Introduction

Fugro Technical Services Limited was commissioned by the client, [REDACTED] to conduct a series of tests on silicone sealant to BS EN ISO 11600 : 2003 + A1 : 2011. The test methods and specifications were based on ISO 8340 : 1984, ISO 10590 : 1991, and ISO 11600 : 2002 (E) Table 3 which are for use in building joint generally (CLASS 25HM).

Clear float glass, cement mortar and aluminium panels were used for the test surfaces.

Description of Sample : Dow Corning 796 Neutral Silicone (Class 25LM)
Primer : DOW CORNING 1200-OS PRIMER CLEAR
Date Received of Sample : 21 April 2017

2.0 Summary of Test Results

Test Item	Test Method	Test Surface	Sample Condition (°C)	Lab Sample I.D.	Result
Tensile properties at maintained extension test (Method A)	ISO 8340: 1984 with modification the testing temperature to 23°C of condition (Class 25HM)	Concrete	23	ST170356/25-27	Fail
			-20	ST170356/28-30	Fail
Adhesion and cohesion properties at maintained extension after water immersion test (Method A)	ISO 10590 : 1991 (Class 25HM)	Concrete	23	ST170356/58-60	Fail

Remark : The test results relate only to the samples tested.

Checked by : L.Y. Tang

Certified by: [Signature]

Chan Chun Wai Ivan
Manager (Product Testing Laboratory)

Date : 1 / 11 / 2017

Date : 1.11.2017



FUGRO TECHNICAL SERVICES LIMITED

Fugro Development Centre,
5 Lok Yi Street, Tai Lam,
Tuen Mun, N.T.,
Hong Kong.

Tel : +852 2450 8233
Fax : +852 2450 6138
E-mail : matlab@fugro.com
Website : www.fugro.com

MaterialLab

Client Ref. : --

Page 2 of 5

Report No. : 171832ST170356(1)

3.1 Tensile Properties At Maintained Extension Test (Method A)

(ISO 8340 : 1984 with modification the testing temperature to 23°C of condition (Class 25HM))

One group of samples were stored at -20°C for 4 hours in advance and then they were tested under the ambient condition at 23°C, followed by storage at -20°C for 24 hours for visual assessment.

Lab. Sample I.D. : ST170356/25-30
Date Received : 21 April 2017
Date Test Started : 20 June 2017
Date Test Completed : 21 June 2017

Lab. Sample I.D.	Test Surface	Storage temperature before and after testing (°C)	Extension (%)	Failure Area of Depth (mm)	Observation after 24 hours extension	Specification
ST170356/25	Concrete	23	100	0	No adhesion or cohesion failure	No loss of adhesion or cohesion in the depth of the sealant exceeds 2 mm.
ST170356/26	Concrete	23	100	0	No adhesion or cohesion failure	
ST170356/27	Concrete	23	100	12	Adhesion failure	
ST170356/28	Concrete	-20	100	0	No adhesion or cohesion failure	
ST170356/29	Concrete	-20	100	12	Adhesion failure	
ST170356/30	Concrete	-20	100	12	Adhesion failure	

Note : The test results **do not comply** with the requirements of ISO 11600 : 2002 (E) Table 3 (Class 25HM)

FUGRO TECHNICAL SERVICES LIMITED

Fugro Development Centre,
5 Lok Yi Street, Tai Lam,
Tuen Mun, N.T.,
Hong Kong.

Tel : +852 2450 8233
Fax : +852 2450 6138
E-mail : matlab@fugro.com
Website : www.fugro.com

MaterialLab

Client Ref. : --

Page 3 of 5

Report No. : 171832ST170356(1)

3.2 Adhesion/ Cohesion Properties At Maintained Extension After Water Immersion Test (Method A)

(ISO 10590 : 1991 (Class 25HM))

In distilled water at 23°C for 4 days, followed by storage at 23°C and 50% relative humidity for 1 day before test.

Lab. Sample I.D. : ST170356/58-60

Date Received : 21 April 2017

Date Test Started : 22 June 2017

Date Test Completed : 28 June 2017

Lab. Sample I.D.	Test Surface	Storage temperature before and after testing (°C)	Extension (%)	Failure Area of Depth (mm)	Observation after 24 hours extension	Specification
ST170356/58	Concrete	23	100	0	No adhesion failure or cohesion	No loss of adhesion or cohesion in the depth of the sealant exceeds 2 mm
ST170356/59	Concrete	23	100	12	Adhesion failure	
ST170356/60	Concrete	23	100	12	Adhesion failure	

Note : The test results **do not comply** with the requirement of ISO 11600 : 2002 (E) Table 3 (Class 25HM)

FUGRO TECHNICAL SERVICES LIMITED

Fugro Development Centre,
5 Lok Yi Street, Tai Lam,
Tuen Mun, N.T.,
Hong Kong.

Tel : +852 2450 8233
Fax : +852 2450 6138
E-mail : matlab@fugro.com
Website : www.fugro.com

MaterialLab

Client Ref. : --
Report No. : 171832ST170356(1)

Page 4 of 5

4.0 Record Photographs

(Tensile Properties At Maintained Extension Test (Method A))



Sample After Test
Sample I.D.: ST170356/25-27



Sample After Test
Sample I.D.: ST170356/25-27

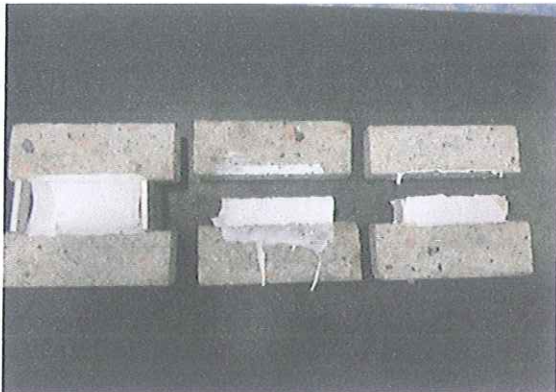

Sample After Test
Sample I.D.: ST170356/28-30



Sample After Test
Sample I.D.: ST170356/28-30

FUGRO TECHNICAL SERVICES LIMITED

Fugro Development Centre,
5 Lok Yi Street, Tai Lam,
Tuen Mun, N.T.,
Hong Kong.

Tel : +852 2450 8233
Fax : +852 2450 6138
E-mail : mallab@fugro.com
Website : www.fugro.com

MaterialLab

Client Ref. : --
Report No. : 171832ST170356(1)

Page 5 of 5

4.0 Record Photographs

Adhesion/ Cohesion Properties At Maintained Extension After
Water Immersion Test (Method A)



Sample After Test
Sample I.D.: ST170356/58-60

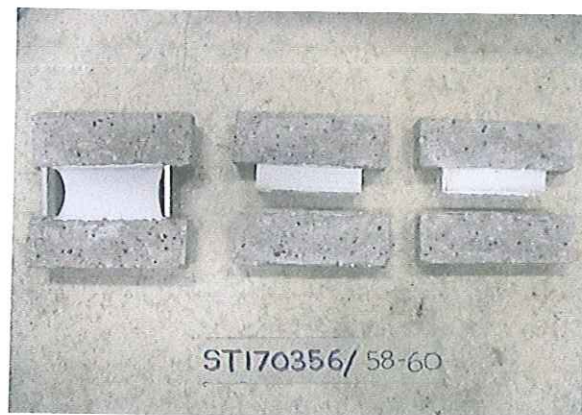

Sample After Test
Sample I.D.: ST170356/58-60

****End of Report****

Dowsil 796 香港工程案例

1	香港E屋	26	馬寶道
2	界限街	27	荃灣橫龍街
3	青衣物流中心	28	元朗510北站
4	沙浦北	29	赤鱸角機場空運中心
5	大角咀福全街	30	嘉善街8號
6	福全街	31	南昌街
7	九肚山	32	半山堅道48號
8	高山道	33	P7017A 蕪湖街88至102號
9	卑路乍街	34	上水新樂街270地盤
10	深灣道9號	35	新界坪峰路Lot938段
11	巴炳頓道	36	上環永樂街
12	將軍澳數據中心	37	TPTL 188,大埔白石角
13	葵昌路	38	葵涌和宜合道119
14	將軍澳天晉	39	TMTL508, 屯門良德街
15	將軍澳95區	40	柴灣道33號
16	馬鞍山白石	41	中環干諾道中47號
17	筲箕灣教堂里	42	天水圍34區
18	觀塘裕民坊	43	沐縉街2號KT1E1地盤 (Dark Gray)
19	白石角225	44	將軍澳消防局 (White)
20	屯門515	45	柴灣道391 (Bronze)
21	TKO 86 (第四期)	46	機場3跑 (Dark Gray)
22	白石-whitehead		
23	北帝街		
24	屯門539		
25	天水圍33		